

## INSTALLATION GUIDELINE FOR TRYMER® SUPERCCEL PHENOLIC INSULATION

### TRYMER® SUPERCCEL PHENOLIC INSULATION IN CHILLED WATER APPLICATIONS (35°F to 60°F) – Vers. 1.0

#### 1 SCOPE

- 1.1 This guideline covers the installation of Trymer® Supercel Phenolic Insulation on chilled water piping systems operating at temperatures of 35 to 60°F in commercial and industrial applications, including associated vessels, tanks, and equipment. Guidelines are provided for both indoor and outdoor applications.
- 1.2 Trymer Supercel Phenolic Insulation is also suitable for use on hot piping systems up to 257°F but the insulation system and installation details for that application are not covered in this document.
- 1.3 Product data sheets and other ITW literature are referenced throughout this guideline. Consult [www.itwinsulation.com](http://www.itwinsulation.com) for the latest version of these documents.
- 1.4 The information contained in this guideline and referenced ITW documents are current as of May, 2012. This guideline is subject to revision without notice. Contact ITW Insulation Systems at 1-800-231-1024 or your local ITW Representative for the most recent version of this guideline or other ITW referenced literature.
- 1.5 Due to the variations in service conditions and use, this guideline may not be pertinent for every application. A design or specifying engineer can create specifications tailored to particular applications or owner's needs. Such a design or specification engineering service may be more familiar with local conditions, budgets, environment, and desired service life of the system allowing them to generate a precise specification.
- 1.6 It is the intent of this document to provide guidelines for the installation of Trymer Supercel Phenolic Insulation and Saran™ CX Vapor Retarder Film and Saran™ CX Tape supplied by ITW Insulation Systems. This guideline may not be suitable and shall not be used for the purpose of installing another insulation manufacturer's products. While supplemental insulation products may be referenced in this guideline, ITW recommends consulting the manufacturers of such products for proper installation and handling.
- 1.7 The insulation contractor shall bring any conflict between the requirements of this guideline and related codes, standards, data sheets, drawings, commercial contracts, specification etc. to the attention of the system owner or design engineer for clarification and resolution.
- 1.8 **This guideline is offered as a guide for the purpose described herein. No warranty of procedures, either expressed or implied is intended. All other express or implied warranties of merchantability or fitness for a particular purpose are disclaimed.**

#### 2 GENERAL

- 2.1 All piping shall be free of foreign substances and free of surface moisture or frost prior to the application of insulation.
- 2.2 All insulation material shall be delivered to the project site in original, unbroken factory packaging labeled with product designation and thickness. The shipping package should not be air-tight. Shipment of materials from the manufacturer to the installation location shall be in weather tight transportation. Insulation materials delivered to the jobsite shall be stored so as to protect the materials from moisture and weather during storage and installation. Insulation material shall be protected from sunlight to avoid UV exposure.
- 2.3 All testing of piping systems shall be completed prior to the installation of the insulation system.
- 2.4 Refer to the insulation thickness charts in Section 5.3 Appendix C to determine recommended insulation thickness for condensation control based on ambient and service conditions.
- 2.5 Refer to the insulation thickness charts in Section 5.4 Appendix D to determine recommended insulation thickness for energy efficiency and energy code compliance based on ambient and service conditions.

#### 3 MATERIALS OF CONSTRUCTION

### **3.1 INSULATION MATERIALS FOR PIPING, FITTINGS, AND VALVES**

- 3.1.1 Insulation shall be Trymer Supercel Phenolic Insulation from ITW Insulation Systems. The insulation shall not use CFC or HCFC blowing agents during the manufacturing process and shall be CFC and HCFC free.
- 3.1.2 Insulation shall meet the requirements of ASTM C-1126, type III, Grade 1 “Standard Specification for Faced or Unfaced Rigid Cellular Phenolic Thermal Insulation”
- 3.1.3 Insulation shall have an ASTM E84 flame spread/smoke developed rating of  $\leq 25/50$  at thicknesses of  $\leq 3$  inches.

### **3.2 FABRICATION OF INSULATION**

- 3.2.1 Insulation shall be fabricated in required shapes from bun stock in accordance with ASTM C-450 “Standard Practice for Prefabrication and Field Fabrication of Thermal Insulating Fitting Covers for NPS Piping, Vessel Lagging, and Dished Head Segments” and C-585 “Standard Practice for Inner and Outer Diameters of Rigid Thermal Insulation for Nominal Sizes of Pipe and Tubing (NPS System)”. Insulation shall be factory fabricated from bun stock.
- 3.2.2 Insulation for piping of size about 16” NPS and smaller shall be fabricated as two mating pieces or half-shells. For insulation of larger size piping, half-shells are acceptable but the insulation can also be supplied as three or more curved segments. Curved segments shall be fabricated per ASTM C450 to fit the contour of the surface to be insulated in equal size pieces with a minimum number of through joints. Fabrication or cutting in the field shall be minimized.
- 3.2.3 Fittings, such as valves, valve stations, flanges, 90° and 45° elbows, and tees shall be two pieces fly-cut or routed as the preferred fabrication method. For diameters too large for fly cutting or routing, the pieces shall be fabricated in two halves with each half made up of mitered sections. Both methods shall be in accordance with ASTM C-450 and ASTM C-585. Larger outer diameter valves and flanges may be slightly oversized and cavities filled with tightly packed loose glass fiber or polyurethane spray foam (see Figure 1 in Appendix B). The size and number of cavities shall be kept to a minimum. Refer to application section 4.1.2 for related additional information.
- 3.2.4 Bun stock shall be stored at normal shop (indoor) conditions for at least 24 hours before fabrication. This will allow the Trymer Supercel Phenolic bun stock to equilibrate to the shop conditions. For best fabrication quality and to maximize flatness, pipe shells shall be cut so that the longitudinal dimension of the pipe shell comes from the 38” long (length) direction of the Trymer Supercel Phenolic bun. The fabricated pipe shells should be aged for 24 hours before vapor retarder attachment. Similarly after fabrication of the fittings/elbows/tees, allow the cut pieces to age for 24 hours before factory application of the vapor retarder to the fabricated pieces. After application of vapor retarder, fabricated pipe shells shall not be stored for more than two months either in the warehouse or at a job site before final installation. During storage all vapor retarder and fabricated insulation must be protected from exposure to sunlight or water.

### **3.3 ADHESIVES, JOINT SEALANTS AND MASTICS**

- 3.3.1 Solvent or water based adhesives, joint sealants, and mastics may be used in contact with Trymer Supercel Phenolic Insulation. All adhesives, joint sealants, and mastics shall remain flexible at the lowest expected exposure temperature.
- 3.3.2 Solvent or water based adhesives may be used to attach the Saran CX Film to the outer surface of the Trymer Supercel Phenolic insulation for factory applied Saran CX Film. Refer to the Saran™ CX installation guidelines. Consult adhesive manufacturer's literature for instructions on handling adhesives including required operating temperatures. Potential adhesives for use in this application include the following, all of which are available from H.B. Fuller Construction Products Inc. ([www.fosterproducts.com](http://www.fosterproducts.com)):
  - a) Childers CP 85 adhesive (solvent adhesive)
  - b) Foster 85-15 adhesive (solvent adhesive)
  - c) Foster 85-50 adhesive (water based adhesive)
  - d) Foster 85-60 adhesive (water based adhesive).
  - e) Foster 85-45 aerosol spray adhesive
- 3.3.3 Where Saran CX vapor retarder is not used or is not practical, on pipes, fittings, tanks and equipment a high performance, low permeance ( $< 0.10$  perms), flexible, water resistant, vapor retarder mastic or coating may be used with reinforcing mesh as the vapor retarder on some or all of the outer surface of the insulation. Typical vapor retarder mastics/coatings are Childers Chil Perm CP-30 Low Odor, Encancel X or V, Chil Perm CP-35, Foster Vapor Safe 30-80, Tite Fit 30-35, Monolar 60-90 or 60-95 all from H.B. Fuller Construction Products

- Inc.([www.fosterproducts.com](http://www.fosterproducts.com) ) or approved equal. Please consult mastic or coating manufacturer for recommend products and application methods.
- 3.3.4 In applications where the ambient environment is typical of conditioned space (i.e. low relative humidity), the use of joint sealant is optional. In high humidity ambient environments or where additional caution against water vapor intrusion is desired, joint sealant shall be used.
- 3.3.5 When joint sealant is used, it shall be a non-hardening vapor retarder type and shall be applied on both insulation longitudinal joints and butt joints to prevent moisture and moisture vapor infiltration. Typical joint sealants are Childers Chil-Joint CP-70, Childers Chil-Byl CP-76, Foster Foamseal 30-45, and Foster Flextra 95-50 all available from H.B. Fuller Construction Products Inc. ([www.fosterproducts.com](http://www.fosterproducts.com)) or approved equal. The joint sealant manufacturer should be consulted for recommended products and application.
- 3.3.6 Joint sealants for PVC jacketing slip joints, shall be vapor retarder type, moisture and water resistant, non-hardening, and flexible with a service temperature range from -50°F to +200°F.
- 3.3.7 Metal jacketing joint sealant (flashing sealant)
- 3.3.7.1 The use of sealant on metal jacketing joints including the joints on Aluminum Elbow Covers is a controversial and unsettled aspect of system design. Use of sealant is a decision that should be made by the specifier/designer of each insulation system.
- 3.3.7.2 For best insulation system performance and resistance to water infiltration, ITW recommends that all metal jacketing joints including those on Aluminum Elbow Covers and the overlap between these covers and the neighboring straight pipe metal jacketing be sealed with an appropriate joint sealant.
- 3.3.7.3 Metal joint sealant should be applied between the overlapping pieces of metal in the joint and not as a caulking bead on the exterior lip of the joint.
- 3.3.7.4 Metal jacketing joint sealant is also used to seal around protrusions and some insulation terminations.
- 3.3.7.5 Where metal joint sealant is used it shall be a vapor retarder type, moisture and water resistant, non-hardening, and flexible. The service temperature range for the metal jacketing joint sealant shall be from -40°F to +250°F. Typical jacketing joint sealants are Childers Chil-Joint CP-70, Childers Chil-Byl CP-76, Foster Foamseal 30-45 and Foster Elastolar 95-44 all available from H.B. Fuller Construction Products Inc. ([www.fosterproducts.com](http://www.fosterproducts.com) ) or approved equal.

## **3.4 VAPOR RETARDER**

- 3.4.1 For pipe, the vapor retarder shall be Saran CX 540 Vapor Retarder Film and Saran CX 520 Vapor Retarder Tape or approved equal unless greater physical strength of the vapor retarder is desired in which case Saran CX 560 Film or approved equal shall be used. Refer to ASTM standards C-755, ASTM C921 and C-1136 for information on selection and specification of vapor retarders. Refer to product literature and installation guidelines on Saran™ CX film and tape for recommended application instructions.
- 3.4.2 Saran CX shall not be left exposed in outdoor applications for longer than 2 weeks.
- 3.4.3 Elbows and fittings shall be spiral wrapped with Saran CX 520 Vapor Retarder Tape. When the nominal insulation outer diameter is 6" or less, use 1" wide Saran CX 520 tape. When the nominal insulation outer diameter is between 6" and 12", use 2" wide Saran CX 520 tape. When the nominal insulation outer diameter is greater than 12", use 3" wide Saran CX 520 tape.
- 3.4.4 Vapor retarder butt joints shall be sealed with 3" wide Saran CX 520 Vapor Retarder Tape applied with a 25% (1 ¼ wraps) circumferential overlap (see Figure 3 in Appendix B).
- 3.4.5 Vapor Retarder shall have a maximum permeance of 0.030 perm.
- 3.4.6 Vapor retarder may be factory or field applied to the outer surface of pipe insulation but factory applied is preferred. Refer to Installation Guideline on Saran CX Vapor Retarder Film for additional information.
- 3.4.7 Where Self Sealing Lap (SSL) tape is used to seal the longitudinal seams of the vapor retarder, all vapor retarder surfaces should be cleaned and free of dust/ grease/ oil/etc before application of the SSL tape to ensure good adhesion between the tape and vapor retarder. The width of the SSL tape shall be 1½" or greater. The recommended SSL tapes can be: Venture SSL 1124, Venture SSL 3693 FLE, Venture SSL 1163, or Venture SSL 514CW. ITW does not recommend the use of mastics as the only means of sealing the longitudinal joint.
- 3.4.8 When outer protective jacketing such as aluminum or PVC is used on pipe, tanks, vessels, or equipment, Saran CX 540 Vapor Retarder Film or approved equal shall be used unless greater physical strength of the vapor retarder is desired in which case Saran CX 560 or approved equal shall be used.
- 3.4.9 When outer protective jacketing is not used, the need for the vapor retarder to have greater physical strength is more important. If greater physical strength is deemed necessary, Saran CX 560 Vapor Retarder Film shall be used.

- 3.4.10 When outer protective jacketing is not used, if a more robust insulation system is desired, wrap 1" wide or greater Saran CX 520 tape or ¾" wide or greater filament tape around the outside circumference of the vapor retarder with a 25% (1 ¼ wraps) circumferential overlap at 18" centers. See Figure 7 for details.
- 3.4.11 ITW does not recommend the use of mastics over Saran CX tape.

## **3.5 PROTECTIVE JACKETING MATERIALS**

### **3.5.1 Indoor Applications**

- 3.5.1.1 On piping systems where mechanical abuse is minimal, Saran CX 540 film can be used as the outer jacketing. See 3.4 for vapor retarder details.
- 3.5.1.2 Where Saran CX film is the outer jacketing, Saran CX 520 tape shall serve as the outer jacketing on all fittings, elbows, valves, caps, etc.
- 3.5.1.3 If protective jacketing is required on piping, tanks, vessels, or equipment such as in industrial applications, it shall be PVC material. Consult jacketing manufacturer for recommended PVC thicknesses. Typical PVC Jacketing thicknesses are 0.010 to 0.030". Jacketing shall be tough and capable of enduring frequent wash-downs with hot water or cleaning agents. All joints of a PVC jacket shall be solvent welded to prevent moisture infiltration into the insulation system. A minimum of two inch overlap shall be provided on all circumferential and longitudinal joints of any PVC jacketing.
- 3.5.1.4 When using PVC jacketing, supply preformed PVC covers for all fittings, tees, elbows, valves, caps, etc. at same PVC thickness as on straight pipe sections.
- 3.5.1.5 PVC protective jacketing shall not be considered a vapor retarder. See 3.4.1 and 3.4.3 for vapor retarder recommendation.
- 3.5.1.6 Neither rivets, screws, staples nor any other fastener capable of penetrating the underlying vapor retarder shall be used to secure the jacketing.
- 3.5.1.7 Saran CX 560 Vapor Retarder Film may be used as a combination vapor retarder and protective jacket unless degree of mechanical abuse is very high. It may be used in lieu of the Saran CX 540 Vapor Retarder Film and the PVC jacketing. Consult ITW for details.
- 3.5.1.8 In situations where an extremely high degrees of mechanical abuse is expected, PVC jacketing is not adequately strong and the jacketing shall be aluminum. See 3.5.2 for details on aluminum jacketing.

### **3.5.2 Outdoor Applications**

- 3.5.2.1 Jacketing shall be aluminum complying with ASTM C1729, Type I, Grade 1 or 2, Class A. Jacketing shall have a 3 mil thick polysurlyn moisture barrier heat laminated to the interior surface. Consult ITW for recommended thicknesses and usage details. Typical thickness is 0.016".
- 3.5.2.2 Aluminum jacketing for elbows/fittings shall preferably be pre-fabricated two-piece pressed elbows complying with ASTM C1729, Type III, Grade 3, Class D. Sectional, factory contoured, or field-fabricated gores shall be an alternative for elbows/fittings. All elbows/fittings shall fit closely around insulation. Aluminum jacketing for all fittings, tees, elbows, valves, caps, etc. shall have a 3 mil polysurlyn or painted moisture barrier on the interior surface.
- 3.5.2.3 Banding for jacketing shall be 0.020" thick by 1/2" wide stainless steel.
- 3.5.2.4 Aluminum protective jacketing shall not be considered a vapor retarder. See 3.4 for vapor retarder information.
- 3.5.2.5 Neither rivets, screws, staples nor any other fastener capable of penetrating the underlying vapor retarder shall be used to secure the aluminum jacketing.

### **3.5.3 Underground Applications**

- 3.5.3.1 Underground jacketing shall be vapor retarder material with chemical resistance to ground water. Products to be used are Saran CX 560 available from ITW Insulation Systems or 50 mil thick self-adhesive laminated modified asphaltic or rubber membrane type vapor retarder product. Typical asphaltic membrane products are IL-50 from Polyguard or C.I. Wrap 50 H.B. Fuller Construction Products or approved equal.
- 3.5.3.2 Trymer Supercel Phenolic Insulation grade shall be selected so that compressive resistance is adequate to withstand the forces exerted by the soil overburden and any surface traffic.
- 3.5.3.3 Backfill around insulation system for a minimum distance of 6" shall be clean sand without contaminants capable of piercing the vapor retarder. For trench details refer to Figure 2 in Appendix B.

## 4 APPLICATION

### 4.1 PIPING – GENERAL

- 4.1.1 Orient longitudinal insulation joints between half sections at the 3 and 9 o'clock position on the pipe.
- 4.1.2 Install pre-fabricated insulation fittings on elbows, tees, and valves. Insulation at fittings shall be the same thickness of Trymer Supercel Phenolic Insulation as on pipe straight sections.
- 4.1.3 Bottom insulation sections in pipe hangers or supports shall be selected to have adequate compressive resistance to withstand the forces exerted. Consult ITW for assistance in identifying the necessary insulation grade to accomplish this. In most cases, standard 2.5 lb/ft<sup>3</sup> Trymer Supercel Phenolic Insulation is adequate for pipe sizes up to 6" NPS, support spacing no greater than 15 ft, saddle length of 12" or greater, and a safety factor of 3X. Sheet metal saddles of sufficient thickness to avoid flexing shall tightly wrap the outer surface of the insulation system in an arc between 120° and 180° depending upon the load. The vapor retarder and jacketing shall be continuous through the pipe support. See Figure 7 and Section 5.5 Appendix E for more information.
- 4.1.4 For factory applied vapor retarder systems, the insulation shall be secured to the pipe using the vapor retarder and butt tape. If a protective jacket is not used, the optional additional tape wrap described in section 3.4.10 can be used to help secure the insulation to the pipe.
- 4.1.5 When vapor retarder is field applied, insulation shall be secured with ¾" wide or greater fiber reinforced tape with 25% circumferential overlap on 12" centers prior to installation of the vapor retarder material.
- 4.1.6 For both factory and field applied Saran CX Vapor Retarder, staggering of the butt joints in the top and bottom insulation sections is not necessary.
- 4.1.7 All insulation shall be tightly butted and free of voids and gaps at all joints. Joint sealer shall not be used to fill imperfections. Vapor retarder must be continuous. Any tape or banding shall be neatly aligned and overall work must be of high quality appearance and workmanship.
- 4.1.8 When insulation joint sealant is used (see section 3.3.4) it shall be applied to all longitudinal and butt joints in a uniform layer across the entire joint surface (length and depth) with no gaps or voids and as thinly and evenly as can be reasonably achieved while ensuring complete contact between the mating insulation pieces being joined and yielding good adhesion. The thickness of wet joint sealant on an unsealed joint face shall not exceed 1/16". After joints are sealed together they shall appear tight and uniform.
- 4.1.9 While not mandatory in chilled water applications, in high humidity environments consideration shall be given to the use of vapor stops on either side of insulation system penetrations like valve stems, at insulation terminations like flanges, and periodically through straight runs of pipe.
- 4.1.10 Elbows and fittings shall be wrapped with Saran CX 520 Vapor Retarder Tape. See Section 3.4.3 for selection of appropriate Saran CX Tape width. Saran CX 520 Tape shall be wrapped in a spiral configuration with minimal overlap of successive courses. When Saran CX Vapor Retarder is factory-applied, lap joint to be sealed with SSL tape. Apply Saran CX 520 tape around the butt joint with a ¼ circumferential overlap. See details in Figure 3 and Figure 4 in Appendix B.
- 4.1.11 When protective jacketing is used, before it can be installed on a portion of the piping, the vapor retarder system on that portion must be complete and continuous.

### 4.2 INDOOR PIPING

- 4.2.1 This section covers indoor areas including, but not limited to, mechanical rooms, process areas and inhabited areas. Consult applicable codes for areas where flame and smoke requirements may apply. Trymer Supercel Phenolic Insulation and Saran CX Vapor Retarder Film and Tape have an ASTM E84 flame spread/smoke developed rating of ≤ 25/50 making them suitable for all applications inside a commercial building including pipe insulation located inside of air plenums.
- 4.2.2 Refer to section 3.5.1 for material specification on indoor Jacketing.
- 4.2.3 Insulation systems on indoor piping, valves, and flanges shall all be covered per jacketing requirements in section 3.5.1.
- 4.2.4 Seal around protrusions, such as valve stems with a full bead of metal jacket joint sealant (see 3.3.7) or silicone sealant.

### 4.3 OUTDOOR PIPING

- 4.3.1 This section covers outdoor areas including but not limited to, process areas, rooftops, and rooftop equipment.
- 4.3.2 Trymer Supercel Phenolic Insulation shall be protected from prolonged exposure to UV light and weather upon



installation.

- 4.3.3 All materials applied in one day shall have the vapor barrier applied the same day. Any exposed insulation shall be temporarily protected with a combination moisture and/or UV barrier such as black polyethylene film to keep rain water out. The film shall be sealed to pipe or equipment.
- 4.3.4 Outdoors, Saran CX Vapor Retarder Film and Tape shall be covered with a jacketing material within two weeks of installation to eliminate long-term exposure to UV light. Refer to section 3.5.2 for material specification on outdoor jacketing.
- 4.3.5 Outdoor metal jacketing overlap shall be a minimum of 2" at butt and longitudinal joints. Jacketing shall be caulked before closing and banding and the joints positioned in an orientation such that the opening points down to naturally shed water.
- 4.3.6 Straight sections of jacketing shall be neatly secured with bands and seals with a maximum spacing of 9" on center. Butt joints shall be secured with bands and seals centered directly over 2" overlap butt joint. Do not use screws, staples or other fasteners capable of penetrating the underlying vapor retarder.

## **4.4 UNDERGROUND PIPING**

- 4.4.1 Refer to section 3.5.3 for jacketing material requirements.
- 4.4.2 Continuity of vapor retarder is of critical importance in underground applications. Insure that back fill does not puncture vapor retarder.
- 4.4.3 Provided correct backfill is used, the use of protective jacketing is not necessary.
- 4.4.4 Install insulation and vapor retarder per section 4.3. For trench detail, see Figure 2 in Appendix B.

## **4.5 TANK, VESSEL, AND EQUIPMENT INSULATION**

- 4.5.1 All insulation materials shall be the same as those used on the pipe associated with the tank, vessel, or equipment.
- 4.5.2 Tank and vessel head segments shall be curved or flat cut to fit in single piece or segments per ASTM C450. Head segments shall be cut so as to eliminate voids at the head section and in a minimum number of pieces so as to eliminate through joints.
- 4.5.3 Prefabricated flat head sections shall be installed at the same thickness as the vessel walls unless thickness calculations indicate they should be installed thicker. Void area behind the flat head shall be filled with spray applied polyurethane foam. Curved segments shall be fabricated to fit the contour of the surface in equal size pieces to go around the vessel with a minimum number of through joints. Cutting in the field shall be minimized. All sections shall be tightly butted and free of voids and gaps. Refer to Figure 5 in Appendix B.
- 4.5.4 Vertical vessels greater than 4 feet in diameter require an insulation support ring welded or bolted around the bottom of the tank to prevent the shell insulation from sliding down.
- 4.5.5 Secure the tank insulation with ½" wide or greater stainless steel bands on 12-inch centers.
- 4.5.6 Install Saran CX Vapor Retarder. Select Saran CX 560 if additional physical strength is required. Tightly wrap the vessel or equipment insulation circumferentially with Saran CX Film. Overlap the seams by a minimum of 2 inches. Seal the overlapped seams with Saran CX 520 Vapor Retarder Tape. On vertical vessels apply the Saran CX Film starting with the bottom course and work upwards. Each course should overlap on top of the one below it thus providing a joint that will naturally shed water.
- 4.5.7 The vapor retarder on curved head sections shall be mastic/fab/mastic or approved alternate. Flat head sections can be covered with Saran CX Film. Lap joints shall be sealed with Saran CX 520 Vapor Retarder Tape.
- 4.5.8 Legs and appendages attached directly to the shell shall be insulated out from the vessel head or wall four times the insulation thickness and the insulation termination sealed with a vapor stop.
- 4.5.9 Indoor tanks, vessels, and equipment, where mechanical abuse is anticipated shall be covered with PVC jacketing per section 3.5.1. Indoor tanks, vessels, and equipment, where mechanical abuse is not anticipated, see section 3.4.9
- 4.5.10 On outdoor equipment use aluminum jacketing per section 3.5.2. Secure aluminum jacketing using ½" wide or greater stainless steel bands on 12-inch centers. Rivets, screws, or other fasteners capable of puncturing the vapor retarder shall not be used to attach jacketing.

## **5 APPENDICES**

### **5.1 APPENDIX A: CORROSION RESISTANT METAL COATINGS**

**5.1.1 GENERAL NOTE** Corrosion of metal pipe, vessels, and equipment under insulation, while not typically caused by the insulation, is still a significant issue that must be considered during the design of any mechanical insulation system. The propensity for corrosion is dependent on many factors including the ambient environment and the operating temperature of the metal. The recommendations below represent the general practice in the industry but are not meant to take the place of proper system design and specification by a qualified design engineer familiar with this type of construction. We recommend that the owner consult such an engineer and have them work closely with the fabricator, the contractor, and ITW to help insure a properly designed, installed, and long-lasting insulation system free of corrosion.

#### **5.1.2 SPECIFIC RECOMMENDATIONS**

**5.1.2.1 Stainless Steel** All 300 series stainless steel shall be coated with an epoxy primer at 5 mil thickness and an epoxy finish coat at 5 mil thickness if operating in a temperature range between 140°F and 300°F or if in a cycling temperature service where the service temperature is between 140° and 300°F for more than 20% of the time. Consult a coating manufacturer for appropriate coating materials and application methods based on the operating temperature range of the equipment.

**5.1.2.2 Carbon Steel** All carbon steel operating at a service temperature between 32°F and 300°F or in cycling temperature service where the service temperature is between 32°F and 300°F for more than 20% of the time shall be at a minimum primer coated with an epoxy coating. Consult a coating manufacturer for appropriate coating materials and application methods for the operating temperature range of the equipment.

**5.2 APPENDIX B: DETAILS** The following details are referenced in the text of this guideline by their Figure numbers. The diagrams included in this section are representative of details used within the industry. However, they are not intended to display the only accepted method of installation but rather to serve more as an example of commonly used and acceptable practices.

## VALVE INSULATION DETAIL (Including Optional Filling of Voids)

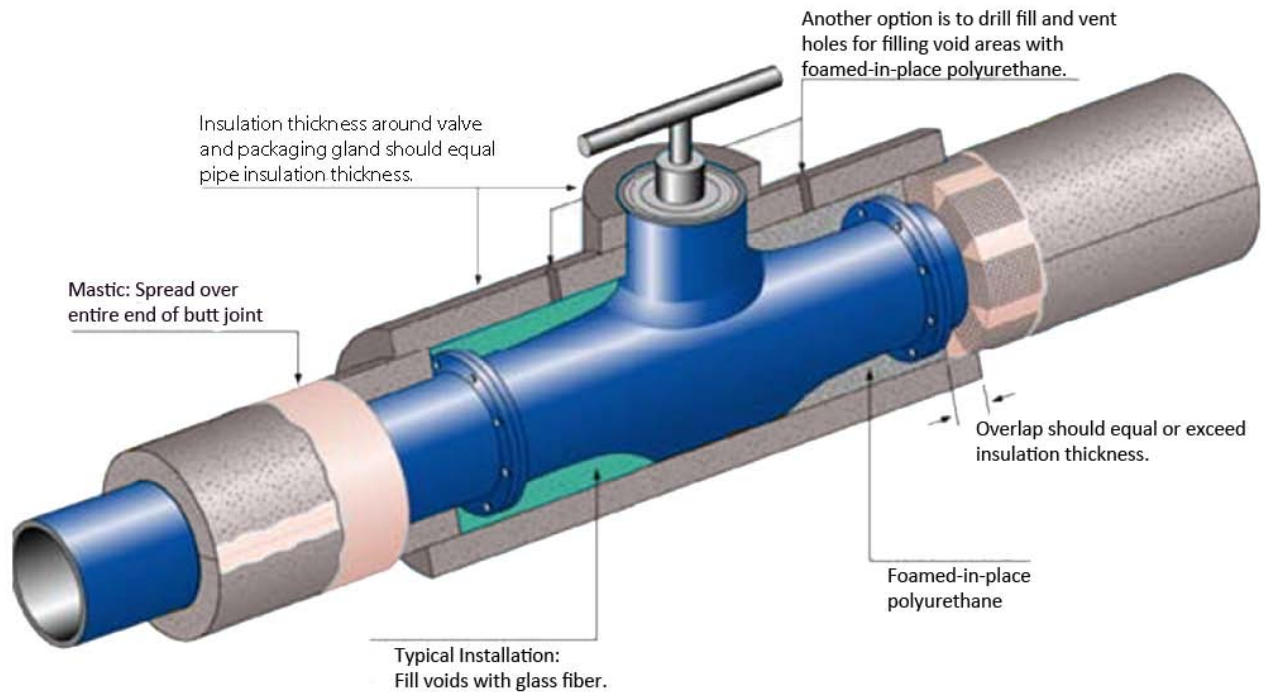

**Figure 1**

### Detail Notes:

- The preferred way to insulate a valve or fitting is with prefabricated tight fitting insulation pieces. If that approach is not used, this detail shows an alternative.
- If desired, voids around valve can be filled with foam-in-place polyurethane or glass fiber.
- Vapor retarder on valve shall be continuous with that on attached pipe.
- Vapor stops are used on either side of the valve to isolate the spread of water entering at the valve stem.
- Seal around valve stem with caulking



## TRENCH DETAILS

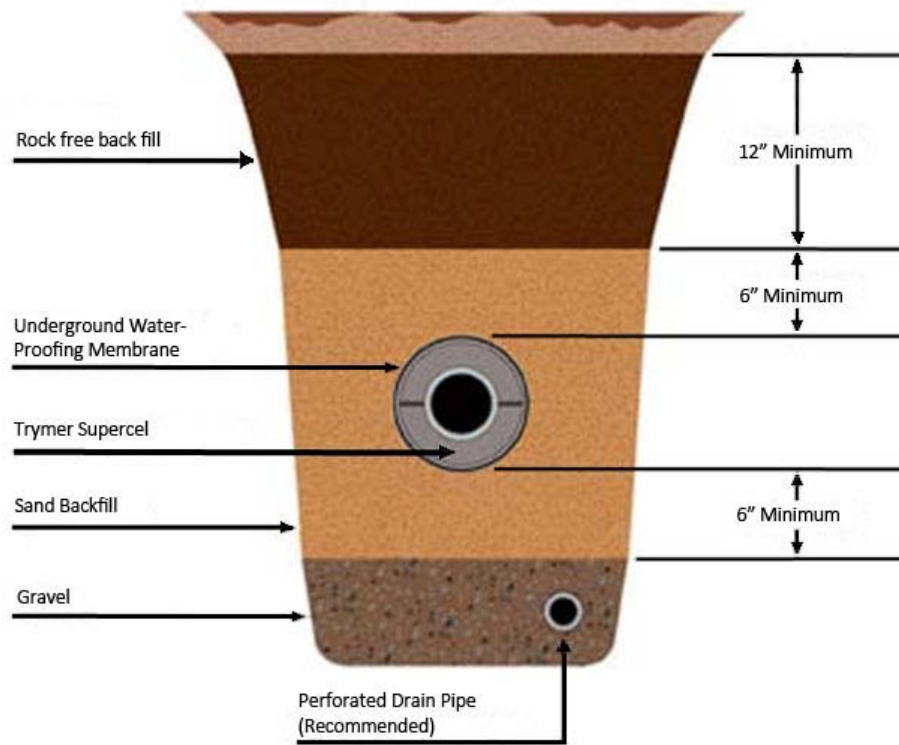
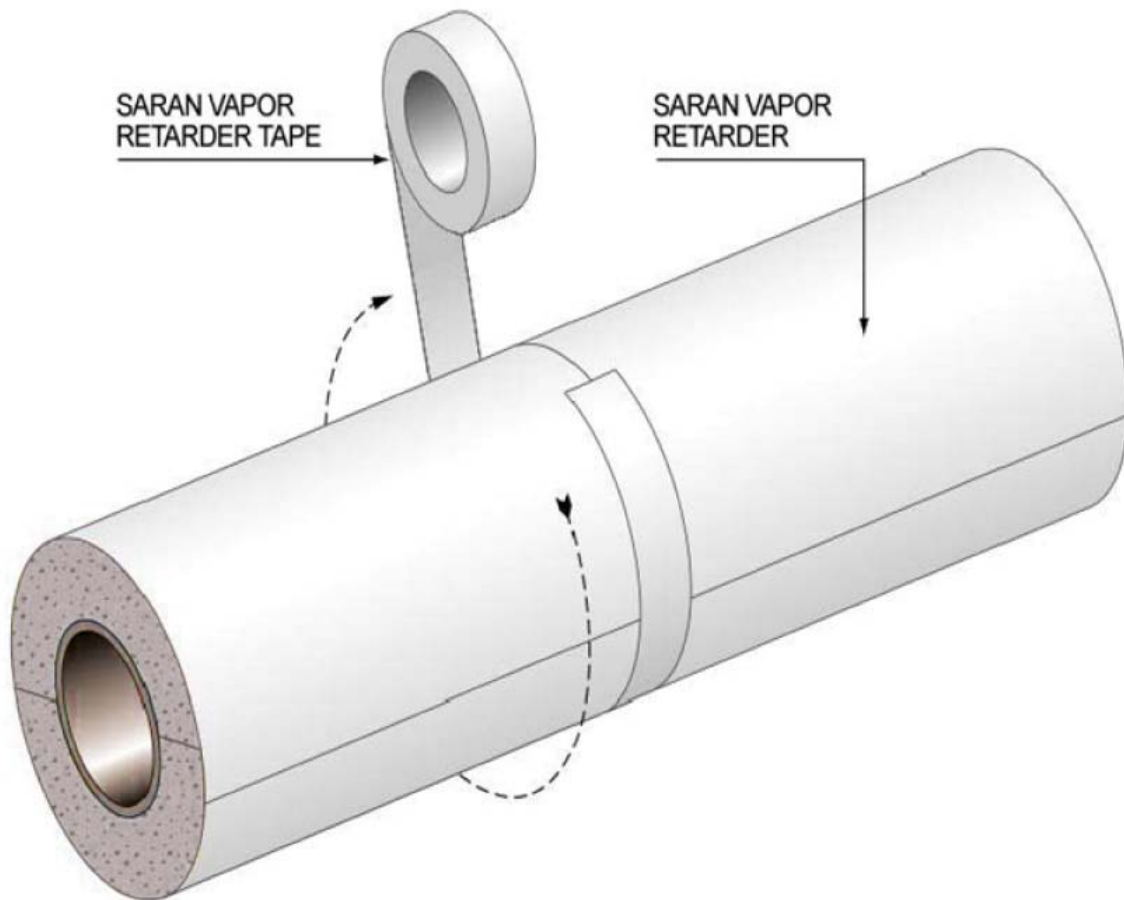

**Figure 2**

### Detail Notes:

- Insulation shall be used in conjunction with a high quality vapor retarder such as Saran CX Film. Protective jacketing products alone are not sufficient for immersion in groundwater. Refer to section 3.5.3 of this guideline for recommended jacketing.
- Back fill around the pipe shall be sand without contaminants that may puncture the vapor retarder.
- Drain tile in trench bottom is recommended to minimize exposure of the insulation system to groundwater.

## FACTORY APPLIED SARAN™ CX FILM AND TAPE APPLICATION



**Figure 3**

### **Detail Notes:**

- Saran CX Vapor Retarder Film lap seal to be SSL tape or liquid adhesive per Installation Guide for Saran CX.
- Saran CX 520 Vapor Retarder Tape shall be used on butt joints.
- Saran CX tape used at butt joints shall be 3 inches wide.
- Wrap tape around butt joint 1.25 times the circumference (1 ¼ wraps).

™Saran CX is a Trademark of The Dow Chemical Company

## FACTORY APPLIED SARAN™ CX FILM WITH SSL TAPE ON LAP JOINT

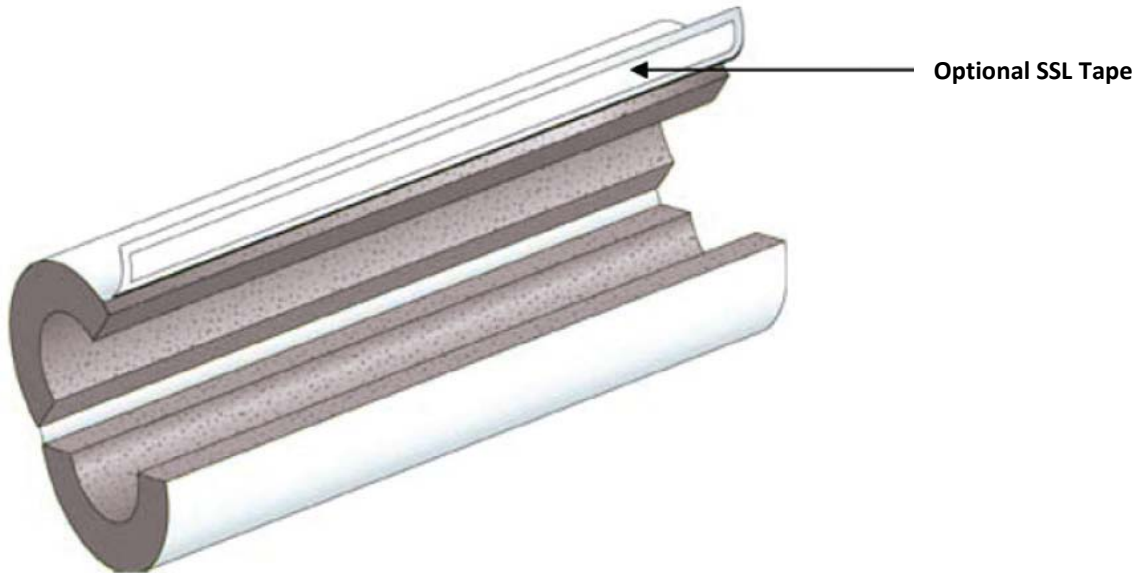

**Figure 4**

### **Detail Notes:**

- Saran CX Vapor Retarder Film must be sealed at the longitudinal joint using SSL tape as shown above or using liquid adhesives.
- Butt joints of Saran CX Film are sealed using 3" wide Saran CX Tape positioned to cover about 1.5" on each side of the joint.

™Saran CX is a Trademark of The Dow Chemical Company

## TANK AND VESSEL INSULATION DETAIL

Figure 5

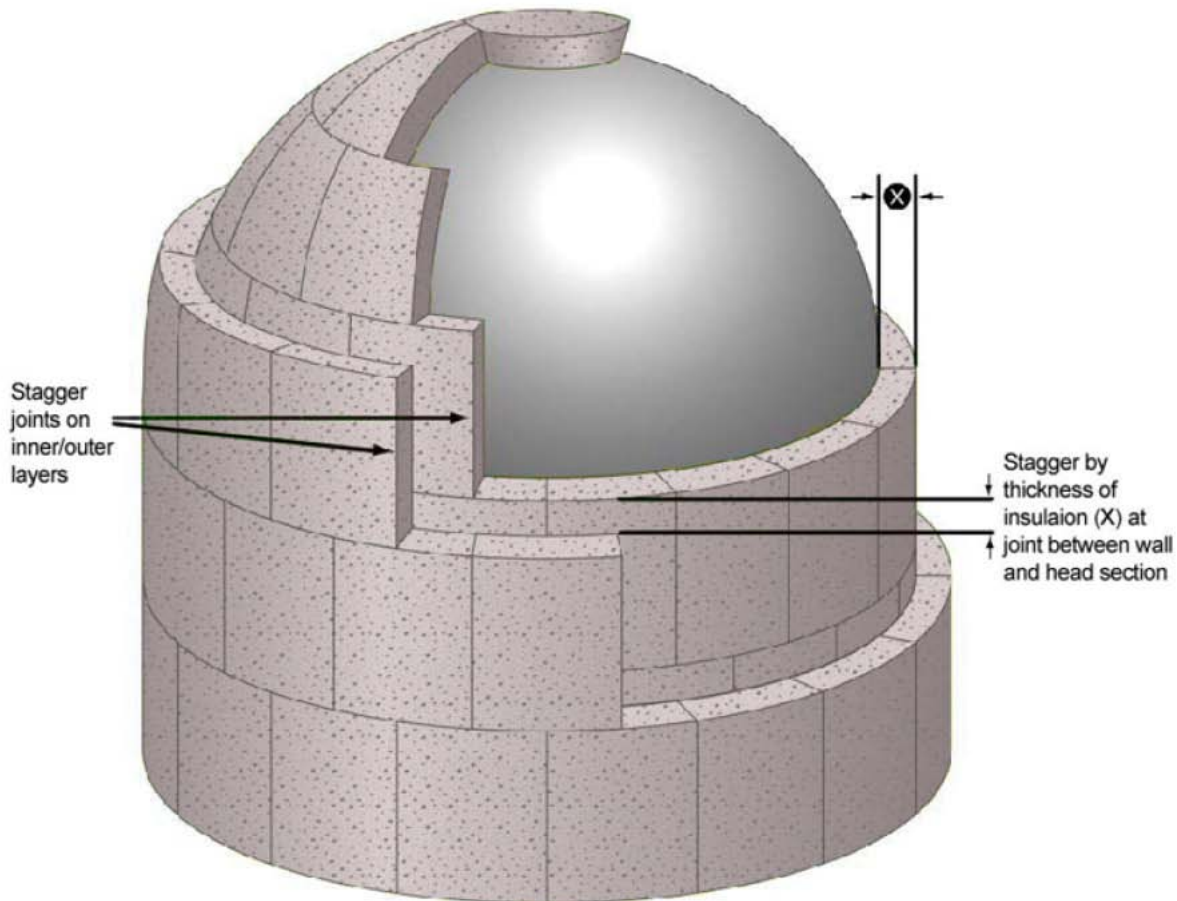

### DETAIL NOTES:

- Insulation thickness on tanks, vessels, and equipment (X in above diagram) shall be that same as the thickness on the associated piping.
- Insulation shall be installed so that the vertical joints in each course are staggered from the joints in the courses on either side by half the width of a full section.
- Where adhesives or sealants are required to bond the insulation sections to the tank head, consult the manufacturer's recommendations on service and application temperatures. Typical adhesives are Foster 81-84 Two Part Urethane Adhesive, Foster Fire Resistive Adhesive, 81-33 or Childers CP-96 Adhesive all available from H B Fuller Construction Products Inc. ([www.fosterproducts.com](http://www.fosterproducts.com)) or approved equal.

## **SARAN™ CX TAPE APPLIED TO BUTT JOINTS**



**Figure 6**

### **DETAIL NOTES:**

- Apply 3” wide SARAN CX 520 Tape to butt joints with a 25% circumferential overlap (1 ¼ wraps).

™Saran CX is a Trademark of The Dow Chemical Company



## HANGER / SUPPORT WITH CONTINUOUS VAPOR RETARDER AND HIGH DENSITY INSULATION INSERT

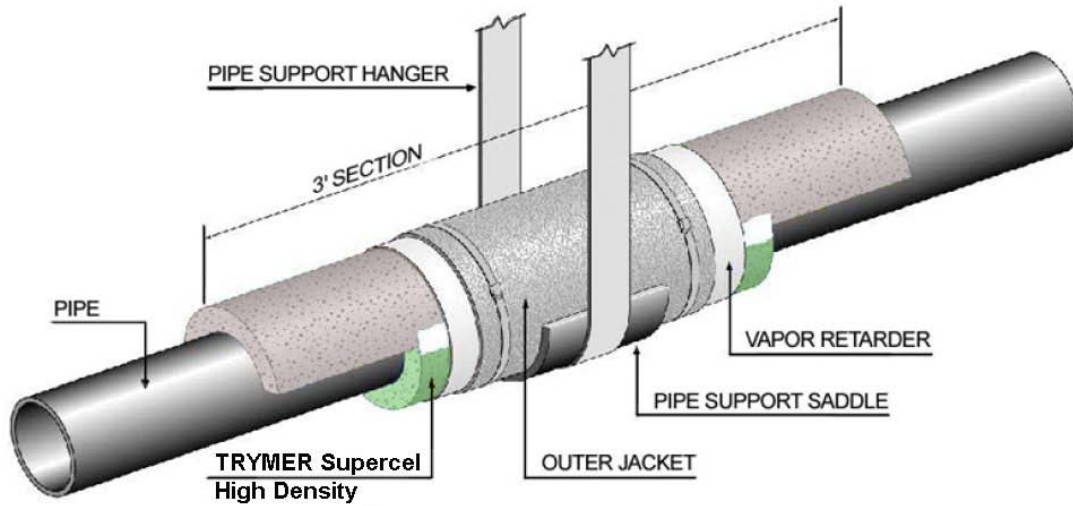

**Figure 7**

### DETAIL NOTES:

- Use insulation in bottom of support of sufficient compressive strength to resist forces exerted by weight of pipe and contents.
- For smaller diameter pipe and shorter spans between supports, standard 2.5 lb/ft<sup>3</sup> Trymer Supercel Phenolic may be sufficient. For larger diameter pipe and longer spans, higher density grades of Trymer Supercel Phenolic Insulation may be necessary.
- Contact ITW for assistance in determining the grade of Trymer Supercel Phenolic Insulation necessary in supports.
- Vapor Retarder and Jacketing shall be installed in continuous fashion through the pipe support.

## **5.3 APPENDIX C: CONDENSATION CONTROL THICKNESS TABLES**

The following tables show the insulation thickness necessary to prevent condensation on the outer surface of the insulation system (vapor retarder or jacketing). These thickness recommendations are based on various design conditions that are shown with each table. A number of assumptions are also made, including proper system design and installation. There may be additional factors the tables do not address that could influence the end results. These thickness tables are not meant to replace proper system design and specification by a qualified design engineer familiar with specific ambient design parameters for a given locality. We recommend that you consult such an engineer and have them work closely with the contractor, and ITW to help insure a properly designed, installed, and long-lasting insulation system. Thickness calculations are performed using a software program that uses heat flow algorithms based on ASTM C680. The required insulation thicknesses do not include a safety factor. Actual operating conditions can vary. Consult a design engineer for an appropriate safety factor.

For chilled water applications, heat gain limits are typically dictated by energy codes such as ASHRAE 90.1 or local codes based on the International Energy Conservation Code. Thicknesses of Trymer Supercel Phenolic Insulation required to comply with these energy codes are shown in 5.4 Appendix D.

### Tables Included:

Table I.D. #	General Location	Ambient Conditions			Jacket & Emittance	Pipe Temp. (°F)
		Temp (°F)	R.H. (%)	Wind (mph)		
1	Indoors	75	70-85	0	Saran CX or PVC (0.9)	35-50
2	Indoors	90	70-85	0	Saran CX or PVC (0.9)	35-50
3	Outdoors	90	75-90	7	Aluminum (0.1)	35-50
4	Outdoors	100	75-90	7	Aluminum (0.1)	35-50

**TABLE #1**

**Trymer Supercel Phenolic Insulation Under the Following Indoor Conditions**

Ambient Temp = 75°F

Outer surface = Saran, PVC, ASJ, or mastic ( $\epsilon = 0.90$ )

Ambient Relative Humidity = 70, 75, 80, & 85%

Wind Velocity = 0 mph

Dewpoints = 64.6, 66.6, 68.4, & 70.2°F

Geometry = Horizontal Pipe

**Insulation Thickness In Inches Necessary To Prevent Condensation**

NPS (in)	70% Relative Humidity				75% Relative Humidity				80% Relative Humidity				85% Relative Humidity			
	Service Temperature (°F)				Service Temperature (°F)				Service Temperature (°F)				Service Temperature (°F)			
	35	40	45	50	35	40	45	50	35	40	45	50	35	40	45	50
0.5	0.5	0.5	0.5	0.5	0.5	0.5	0.5	0.5	0.5	0.5	0.5	0.5	1	0.5	0.5	0.5
0.75	0.5	0.5	0.5	0.5	0.5	0.5	0.5	0.5	0.5	0.5	0.5	0.5	1	1	1	0.5
1	0.5	0.5	0.5	0.5	0.5	0.5	0.5	0.5	0.5	0.5	0.5	0.5	1	1	0.5	0.5
1.25	0.5	0.5	0.5	0.5	0.5	0.5	0.5	0.5	0.5	0.5	0.5	0.5	1	0.5	0.5	0.5
1.5	0.5	0.5	0.5	0.5	0.5	0.5	0.5	0.5	0.5	0.5	0.5	0.5	1	1	0.5	0.5
2	0.5	0.5	0.5	0.5	0.5	0.5	0.5	0.5	0.5	0.5	0.5	0.5	1	1	0.5	0.5
2.5	0.5	0.5	0.5	0.5	0.5	0.5	0.5	0.5	0.5	0.5	0.5	0.5	1	1	0.5	0.5
3	0.5	0.5	0.5	0.5	0.5	0.5	0.5	0.5	0.5	1	0.5	0.5	0.5	1	1	0.5
4	0.5	0.5	0.5	0.5	0.5	0.5	0.5	0.5	0.5	0.5	0.5	0.5	1	1	1	0.5
6	0.5	0.5	0.5	0.5	0.5	0.5	0.5	0.5	0.5	1	0.5	0.5	0.5	1	1	0.5
8	0.5	0.5	0.5	0.5	0.5	0.5	0.5	0.5	0.5	1	0.5	0.5	0.5	1	1	0.5
10	0.5	0.5	0.5	0.5	0.5	0.5	0.5	0.5	0.5	1	0.5	0.5	0.5	1	1	0.5
12	0.5	0.5	0.5	0.5	0.5	0.5	0.5	0.5	0.5	0.5	0.5	0.5	1	1	0.5	0.5
14	0.5	0.5	0.5	0.5	0.5	0.5	0.5	0.5	0.5	1	1	0.5	0.5	1	1	1
16	0.5	0.5	0.5	0.5	0.5	0.5	0.5	0.5	0.5	1	1	0.5	0.5	1	1	1
18	0.5	0.5	0.5	0.5	0.5	0.5	0.5	0.5	0.5	1	1	0.5	0.5	1	1	1
20	0.5	0.5	0.5	0.5	0.5	0.5	0.5	0.5	0.5	1	1	0.5	0.5	1	1	1
24	0.5	0.5	0.5	0.5	0.5	0.5	0.5	0.5	0.5	1	1	0.5	0.5	1	1	1
30	0.5	0.5	0.5	0.5	0.5	0.5	0.5	0.5	0.5	1	1	0.5	0.5	1	1	1
36	0.5	0.5	0.5	0.5	0.5	0.5	0.5	0.5	0.5	1	1	0.5	0.5	1	1	1
Tk. Side	0.5	0.5	0.5	0.5	0.5	0.5	0.5	0.5	0.5	1	0.5	0.5	0.5	1	1	0.5
Tk. Top	0.5	0.5	0.5	0.5	0.5	0.5	0.5	0.5	0.5	1	1	0.5	0.5	1	1	1
Tk. Bot.	0.5	0.5	0.5	0.5	0.5	0.5	0.5	0.5	0.5	1	0.5	0.5	0.5	1	1	0.5

Trymer Supercel Phenolic Insulation may not be available in 0.5” thickness depending on pipe size and fabricator/contractor preferences. Even though sometimes not available, these thicknesses are shown in the above table to demonstrate how readily Trymer Supercel Phenolic Insulation yields condensation control at thicknesses substantially less than that of other insulation materials. When Trymer Supercel Phenolic Insulation is used at thicknesses greater than the minimum indicated in this table, additional energy savings will result and condensation will be prevented to even harsher conditions.

**TABLE #2**

**Trymer Supercel Phenolic Insulation Under the Following Indoor Conditions**

Ambient Temp = 90°F

Outer surface = Saran, PVC, ASJ, or mastic ( $\epsilon = 0.90$ )

Ambient Relative Humidity = 70, 75, 80, & 85%

Wind Velocity = 0 mph

Dewpoints = 78.9, 81.0, 83.0, & 84.9°F

Geometry = Horizontal Pipe

**Insulation Thickness In Inches Necessary To Prevent Condensation**

NPS (in)	70% Relative Humidity				75% Relative Humidity				80% Relative Humidity				85% Relative Humidity			
	Service Temperature (°F)				Service Temperature (°F)				Service Temperature (°F)				Service Temperature (°F)			
	35	40	45	50	35	40	45	50	35	40	45	50	35	40	45	50
0.5	0.5	0.5	0.5	0.5	0.5	0.5	0.5	0.5	0.5	0.5	0.5	0.5	1	1	1	0.5
0.75	0.5	0.5	0.5	0.5	0.5	0.5	0.5	0.5	0.5	1	1	0.5	0.5	1	1	1
1	0.5	0.5	0.5	0.5	0.5	0.5	0.5	0.5	0.5	0.5	0.5	0.5	1	1	1	1
1.25	0.5	0.5	0.5	0.5	0.5	0.5	0.5	0.5	0.5	0.5	0.5	0.5	1	1	1	0.5
1.5	0.5	0.5	0.5	0.5	0.5	0.5	0.5	0.5	0.5	1	1	0.5	0.5	1	1	1
2	0.5	0.5	0.5	0.5	0.5	0.5	0.5	0.5	0.5	1	0.5	0.5	0.5	1	1	1
2.5	0.5	0.5	0.5	0.5	0.5	0.5	0.5	0.5	0.5	1	0.5	0.5	0.5	1	1	1
3	0.5	0.5	0.5	0.5	0.5	0.5	0.5	0.5	0.5	1	1	1	0.5	1	1	1
4	0.5	0.5	0.5	0.5	0.5	0.5	0.5	0.5	0.5	1	1	0.5	0.5	1	1	1
6	0.5	0.5	0.5	0.5	1	0.5	0.5	0.5	0.5	1	1	1	0.5	1	1	1
8	0.5	0.5	0.5	0.5	1	0.5	0.5	0.5	0.5	1	1	1	0.5	1	1	1
10	0.5	0.5	0.5	0.5	1	0.5	0.5	0.5	0.5	1	1	1	1	1.5	1	1
12	0.5	0.5	0.5	0.5	0.5	0.5	0.5	0.5	0.5	1	1	0.5	0.5	1	1	1
14	0.5	0.5	0.5	0.5	1	0.5	0.5	0.5	0.5	1	1	1	1	1.5	1	1
16	0.5	0.5	0.5	0.5	1	0.5	0.5	0.5	0.5	1	1	1	1	1.5	1	1
18	0.5	0.5	0.5	0.5	1	1	0.5	0.5	0.5	1	1	1	1	1.5	1	1
20	0.5	0.5	0.5	0.5	1	1	0.5	0.5	0.5	1	1	1	1	1.5	1	1
24	0.5	0.5	0.5	0.5	1	1	0.5	0.5	0.5	1	1	1	1	1.5	1	1
30	0.5	0.5	0.5	0.5	1	1	0.5	0.5	0.5	1	1	1	1	1.5	1	1
36	0.5	0.5	0.5	0.5	1	1	0.5	0.5	0.5	1	1	1	1	1.5	1.5	1
Tk. Side	0.5	0.5	0.5	0.5	1	0.5	0.5	0.5	0.5	1	1	1	1	1.5	1	1
Tk. Top	0.5	0.5	0.5	0.5	1	1	0.5	0.5	0.5	1	1	1	1	1.5	1.5	1
Tk. Bot.	0.5	0.5	0.5	0.5	0.5	0.5	0.5	0.5	0.5	1	1	1	0.5	1	1	1

Trymer Supercel Phenolic Insulation may not be available in 0.5” thickness depending on pipe size and fabricator/contractor preferences. Even though sometimes not available, these thicknesses are shown in the above table to demonstrate how readily Trymer Supercel Phenolic Insulation yields condensation control at thicknesses substantially less than that of other insulation materials. When Trymer Supercel Phenolic Insulation is used at thicknesses greater than the minimum indicated in this table, additional energy savings will result and condensation will be prevented to even harsher conditions.

**TABLE #3**

**Trymer Supercel Phenolic Insulation Under the Following Outdoor Conditions**

Ambient Temp = 90°F                                      Outer surface = Aluminum, oxidized (ε = 0.10)  
 Ambient Relative Humidity = 75, 80, 85, & 90%      Wind Velocity = 7 mph  
 Dewpoints = 81.0, 83.0, 84.9, & 86.6°F            Geometry = Horizontal Pipe

**Insulation Thickness In Inches Necessary To Prevent Condensation**

NPS (in)	75% Relative Humidity				80% Relative Humidity				85% Relative Humidity				90% Relative Humidity			
	Service Temperature (°F)				Service Temperature (°F)				Service Temperature (°F)				Service Temperature (°F)			
	35	40	45	50	35	40	45	50	35	40	45	50	35	40	45	50
0.5	0.5	0.5	0.5	0.5	0.5	0.5	0.5	0.5	1	1	0.5	0.5	1.5	1	1	1
0.75	0.5	0.5	0.5	0.5	1	1	0.5	0.5	1	1	1	1	1.5	1.5	1.5	1
1	0.5	0.5	0.5	0.5	0.5	0.5	0.5	0.5	1	1	1	1	1.5	1.5	1	1
1.25	0.5	0.5	0.5	0.5	0.5	0.5	0.5	0.5	1	1	1	0.5	1.5	1.5	1.5	1.5
1.5	0.5	0.5	0.5	0.5	1	1	0.5	0.5	1	1	1	1	1.5	1.5	1.5	1
2	0.5	0.5	0.5	0.5	1	0.5	0.5	0.5	1	1	1	1	1.5	1.5	1.5	1
2.5	0.5	0.5	0.5	0.5	1	0.5	0.5	0.5	1	1	1	1	1.5	1.5	1.5	1.5
3	0.5	0.5	0.5	0.5	1	1	1	0.5	1	1	1	1	2	1.5	1.5	1.5
4	0.5	0.5	0.5	0.5	1	1	1	1	0.5	1	1	1	2	1.5	1.5	1.5
6	1	0.5	0.5	0.5	1	1	1	1	1.5	1.5	1	1	2	2	2	1.5
8	1	1	0.5	0.5	1	1	1	1	1.5	1.5	1	1	2	2	2	1.5
10	1	1	0.5	0.5	1	1	1	1	1.5	1.5	1.5	1	2	2	2	1.5
12	0.5	0.5	0.5	0.5	1	1	1	0.5	1.5	1.5	1	1	2.5	2	2	1.5
14	1	1	0.5	0.5	1	1	1	1	1.5	1.5	1.5	1	2.5	2.5	2	2
16	1	1	1	0.5	1	1	1	1	1.5	1.5	1.5	1	2.5	2.5	2	2
18	1	1	1	0.5	1	1	1	1	1.5	1.5	1.5	1	2.5	2.5	2	2
20	1	1	1	0.5	1	1	1	1	1.5	1.5	1.5	1.5	2.5	2.5	2	2
24	1	1	1	0.5	1	1	1	1	1.5	1.5	1.5	1.5	2.5	2.5	2.5	2
30	1	1	1	0.5	1	1	1	1	1.5	1.5	1.5	1.5	2.5	2.5	2.5	2
36	1	1	1	0.5	1	1	1	1	1.5	1.5	1.5	1.5	3	2.5	2.5	2
Tk. Side	1	0.5	0.5	0.5	1	1	1	1	1.5	1.5	1	1	2.5	2	2	1.5
Tk. Top	1	1	1	1	1.5	1.5	1	1	2	2	1.5	1.5	3.5	3	2.5	2.5
Tk. Bot.	0.5	0.5	0.5	0.5	1	1	0.5	0.5	1	1	1	1	2	1.5	1.5	1.5

Trymer Supercel Phenolic Insulation may not be available in 0.5” thickness depending on pipe size and fabricator/contractor preferences. Even though sometimes not available, these thicknesses are shown in the above table to demonstrate how readily Trymer Supercel Phenolic Insulation yields condensation control at thicknesses substantially less than that of other insulation materials. When Trymer Supercel Phenolic Insulation is used at thicknesses greater than the minimum indicated in this table, additional energy savings will result and condensation will be prevented to even harsher conditions.

Maximum thickness of a single layer of Trymer Supercel Phenolic Insulation shall be 2.5 inches.





## 5.4 APPENDIX D: ENERGY EFFICIENCY THICKNESS TABLES

For chilled water applications, heat gain limits are typically dictated by energy efficiency codes such as ASHRAE 90.1 or local codes based on the International Energy Conservation Code. Thicknesses of Trymer Supercel Phenolic Insulation required to comply with these energy codes are shown in the tables below.

Note that the tables in this section show ONLY the thickness necessary for compliance to the ASHRAE 90.1 Standard or the International Energy Conservation Code. These thicknesses do NOT guarantee that condensation control will be achieved.

### **Pipe Insulation Thickness Requirements from ASHRAE 90.1, 2007**

(Adjusted as required by 90.1 for the superior thermal conductivity of Trymer Supercel Phenolic)

Fluid Operating Temperature Range (°F)	Nominal Pipe or Tube Size (in.)				
	<1	1 to <1-1/2	1-1/2 to <4	4 to <8	≥8
<b>Heating Systems (Steam, Steam Condensate, and Hot Water)</b>					
251-350	n.a.	n.a.	n.a.	n.a.	n.a.
201-250	1.00	1.00	1.50	1.50	1.50
141-200	0.50	0.50	0.50	1.00	1.00
105-140	0.25	0.25	0.50	0.50	0.50
<b>Domestic and Service Hot Water Systems</b>					
105+	0.25	0.25	0.50	0.50	0.50
<b>Cooling Systems (Chilled Water, Brine, and Refrigerant)</b>					
40-60	0.25	0.25	0.50	0.50	0.50
<40	0.25	0.50	0.50	0.50	1.00

The minimum thickness requirements in this table are based on energy efficiency considerations only. Condensation control depends on various factors including relative humidity, jacketing material, and wind speed and may not be achieved with these thicknesses. See the tables in 5.3 Appendix C for condensation control thicknesses.

All of the thickness requirements in this table are substantially less than what is required with the base case contained in the Table 6.8.3 of ASHRAE 90.1. This reduction in thickness arises from the substantially better thermal conductivity of Trymer Supercel Phenolic Insulation compared to the values assumed in 90.1 which are based on glass fiber insulation.

Trymer Supercel Phenolic Insulation is not available in 0.25" thickness and may not be available in 0.5" thickness depending on pipe size and fabricator/contractor preferences. Even though sometimes not available, these thicknesses are shown in the above table to demonstrate how readily Trymer Supercel Phenolic Insulation meets the energy efficiency requirements of the ASHRAE 90.1 Standard. When Trymer Supercel Phenolic Insulation is used at thicknesses greater than the minimum indicated in this table, energy savings greater than that required by ASHRAE 90.1 will be achieved.

## Pipe Insulation Thickness Requirements from 2009 IECC

(Adjusted as required for the superior thermal conductivity of Trymer Supercel Phenolic)

Fluid	Nominal Insulation Thickness Required (inches) at These Nominal Pipe Sizes									
	0.5	0.75	1	1.25	1.5	2	2.5	3	4	6
Steam	0.5	0.5	1.0	1.0	1.0	1.5	1.5	1.5	1.5	1.5
Hot Water	0.5	0.5	1.0	1.0	1.0	1.0	1.0	1.0	1.0	1.0
Chilled water, brine or refrigerant	0.5	0.5	1.0	1.0	1.0	1.0	1.0	1.0	1.0	1.0

Fluid	Nominal Insulation Thickness Required (inches) at These Nominal Pipe Sizes									
	8	10	12	14	16	18	20	24	30	36
Steam	1.5	1.5	1.5	1.5	1.5	1.5	1.5	1.5	2.0	2.0
Hot Water	1.0	1.0	1.0	1.0	1.0	1.0	1.0	1.0	1.0	1.0
Chilled water, brine or refrigerant	1.0	1.0	1.0	1.0	1.0	1.0	1.0	1.0	1.0	1.0

The minimum thickness requirements in this table are based on energy efficiency considerations only. Condensation control depends on various factors including relative humidity, jacketing material, and wind speed and may not be achieved with these thicknesses. See the tables in 5.3 Appendix C for condensation control thicknesses.

All of the thickness requirements in this table are substantially less than what is required with the base case contained in the Table 503.2.8 of the 2009 IECC. This reduction in thickness arises from the substantially better thermal conductivity of Trymer Supercel Phenolic Insulation compared to the values assumed in the IECC which are based on glass fiber insulation.

Trymer Supercel Phenolic Insulation may not be available in 0.5” thickness depending on pipe size and fabricator/contractor preferences. Even though sometimes not available, these thicknesses are shown in the above table to demonstrate how readily Trymer Supercel Phenolic Insulation meets the energy efficiency requirements of the IECC. When Trymer Supercel Phenolic Insulation is used at thicknesses greater than the minimum indicated in this table, energy savings greater than that required by the IECC will be achieved.

## **5.5 APPENDIX E: PIPE AND HANGER SUPPORT INFORMATION**

Calculations involving insulation strength as it relates to pipe hangers and supports are complex and involve many variables including:

- |                                      |                                       |
|--------------------------------------|---------------------------------------|
| -Pipe size                           | -Pipe material of construction        |
| -Pipe Schedule                       | -Pipe contents                        |
| -Insulation type                     | -Insulation thickness                 |
| -Span between supports               | -Length of sheet metal support/saddle |
| -Style of sheet metal support/saddle | -Gauge of sheet metal support/saddle  |
| -Safety factor                       | -Insulation compressive strength      |

The large number of variables prevents creation of useful tables related to required insulation density in hangers and supports. However, ITW Insulation Systems can assist with these calculations when needed. Contact your ITW Insulation systems sales representative or our Headquarters office at (800)231-1024 for assistance with this.

For the related issue of sheet metal gauge used in the support/saddle, this is not information which ITW knows firsthand or can calculate. Rather, it is suggested that this information be obtained from the sheet metal or support/saddle supplier or from tables in:

- A. The International Institute of Ammonia Refrigeration Piping Handbook, Chapter 7, Table 7-1, "Shields for Insulated Pipe and Tubing" or
- B. The American Society of Heating, Refrigeration, and Air conditioning Engineers, Handbook of Refrigeration 2006, Chapter 33, Table 14, "Shield Dimensions for Insulated Pipe and Tubing"